

**BECKHOFF** New Automation Technology

# Pluggable system solution for control cabinet-free automation: The MX-System



**MX-System**

# The MX-System: Control cabinet-free automation

For the first time in machine and system engineering, the MX-System enables completely control cabinet-free automation solutions. By consistently combining, applying and further developing Beckhoff's expertise, a holistic, modular pluggable system has been created. The combination of MX-System baseplate and MX-System function modules resulting from the modular construction kit combines all tasks and features of a control cabinet: energy supply, fuse protection and distribution, generation and monitoring of auxiliary voltages, sequence control with the inputs and outputs, control of motors and actuators as well as the connection level for the field devices.

The full system integration of all machine functionalities is achieved via freely selectable IPC, coupler, I/O, motion, relay and system modules, which can be configured and combined suitable for the specific application.

The certification of all components to international standards enables the standardization of control systems around the globe. The consistent systemic approach of the holistically coordinated modules reduces the effort required for planning, assembly, machine installation and maintenance enormously. Since considerably fewer components are required than in traditional control cabinet construction to implement

the same requirements, the entire MX-System is significantly more compact than previous solutions. The system footprint is reduced, and system availability and flexibility are also increased. In each life cycle phase of a control system, the MX-System offers significant advantages over the classic control cabinet.

## Highlights:

- complete control cabinet replacement
- significantly lower installation space requirement
- significantly fewer components
- increased flexibility
- lower maintenance requirements

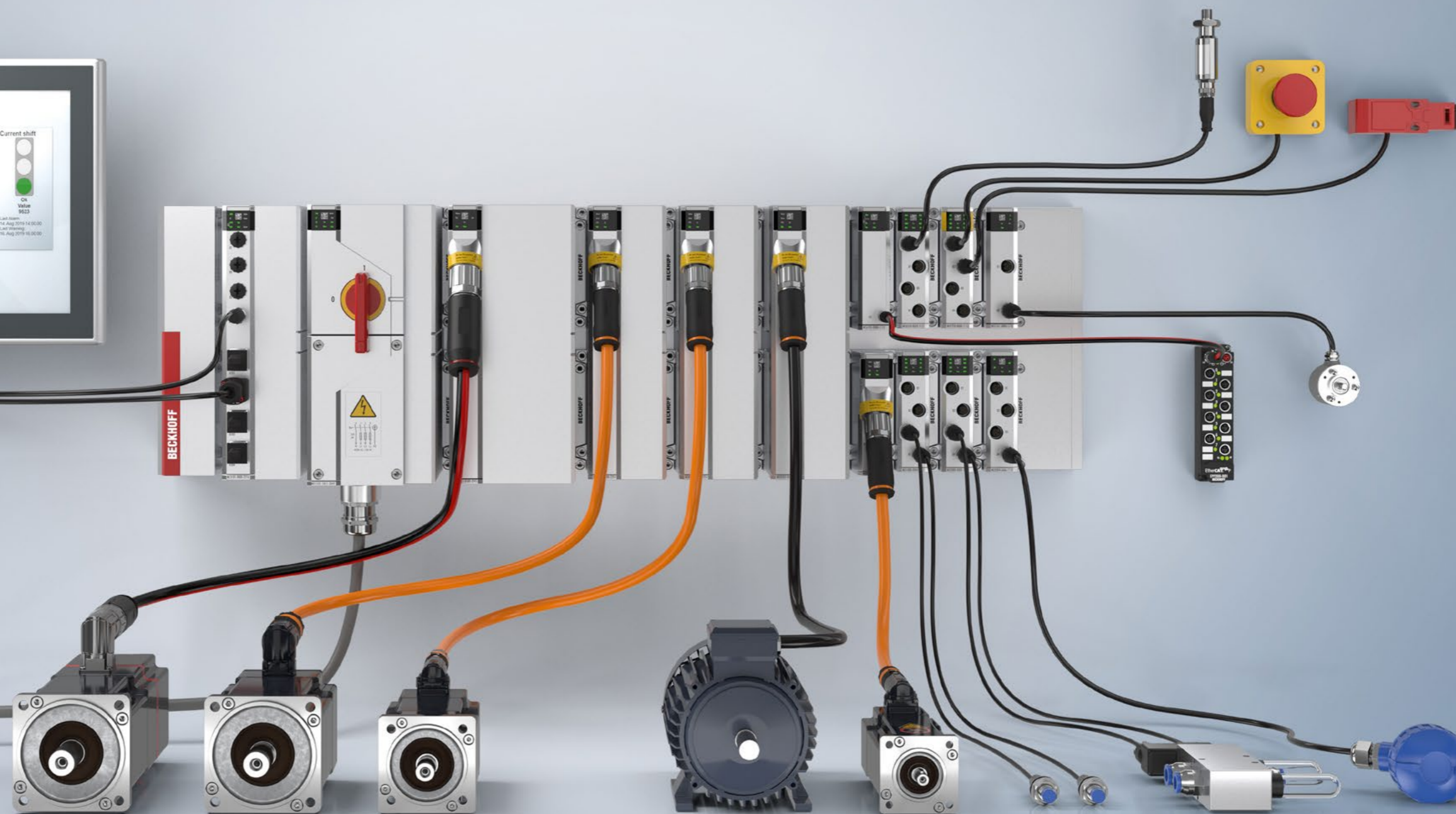
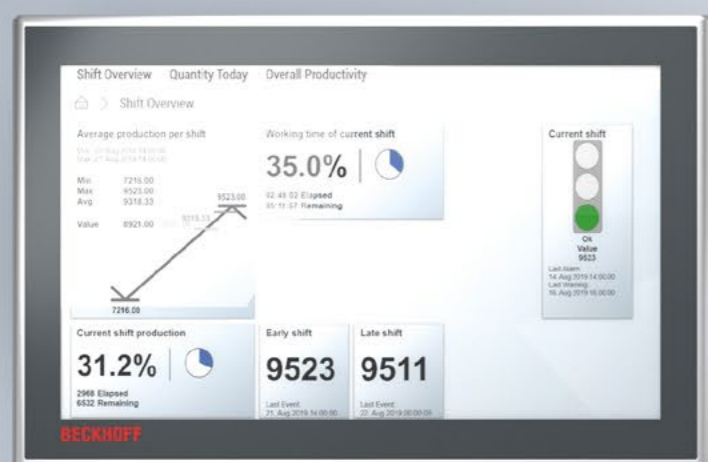

**MX-System**



# The MX-System: Robust automation

The MX-System offers a custom-fit solution for every application, meeting all requirements and thus qualifying for use directly on the machine or system, even in demanding environments. The materials and workmanship of all MX-System components are designed for maximum durability. The robust, chrome-plated or painted metal housings are resistant to oil and cleaning agents, and protect against external influences. The electronics are protected against EMC interference. The tightness of the system is achieved by mounting the MX-System function modules on the MX-System baseplate. A double sealing principle

in the interface between the MX-System baseplate and the MX-System function modules provides increased security against the ingress of moisture and dust.

The robustness of the MX-System simplifies handling along the entire value chain: machine builders can offer an IP67-certified control solution at no extra cost, and users do not need to protect the system separately either during operation or cleaning. The passive cooling throughout also simplifies project planning and handling: the system can be operated at ambient temperatures between 0 °C and 50 °C without additional air

conditioning. The dissipation performance of the system group is maximized by the internal encapsulated ventilation, and hot spots are effectively prevented. An additional internal heater enables safe operation despite the risk of condensation. The temperature range can be extended by active cooling of the MX-System baseplate.

## Highlights:

- no additional housing
- double sealing principle
- optimized connection technology
- can be used in a wide variety of environments



oil- and detergent-resistant

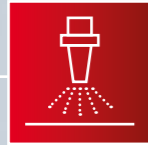

passivated and painted/chrome plated



Al/Zn metal housing

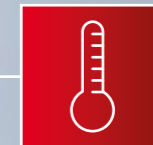

0 ... 50 °C



passive cooling



IP67 dust- and waterproof



# The MX-System: Standardized automation

At the core of each MX-System baseplate are the backplanes, which provide the power voltages via the power backplane, as well as control voltages, communication and diagnostic functionalities (housekeeping) via the data backplane.

The EtherCAT ASICs integrated on the data backplane for each data slot connect each slot to the EtherCAT bus, enable hot-swap functionality of the MX-System function modules and guarantee the real-time capability of the system. Low voltages of 24 V DC or 48 V DC and a maximum current of 30 A are also routed to all data connectors via the data backplane. A module can be supplied with a current of max. 20 A via a

data connector. The power backplane distributes high voltages of 400...480 V AC and 600 V DC at a maximum current of 63 A among all power connectors, and one power connector can supply up to 35 A to an MX-System function module.

Each function module of the MX-System uses a data slot, making it an EtherCAT device and allowing it to be fully parameterized and diagnosed via that slot. Power modules additionally use a power slot.

These standardized interfaces completely replace the internal wiring previously required in the control cabinet. The data and power connectors developed for the MX-System are designed

to provide IP20 contact protection even when no modules and no covers have been mounted on the slots. This also applies to the connectors of the modules. Housekeeping acquires data such as temperature, shock, vibration, barometric pressure and humidity, and enables dew point monitoring, among other features, enabling controlled operation even in more critical ambient conditions. Housekeeping data as well as module-specific and application-specific diagnostic data and parameters can be made available to the machine user directly on a smartphone via Bluetooth.

- Highlights:**
- standardized data interface
  - standardized power interface
  - hot-swap functionality
  - integrated system diagnostics

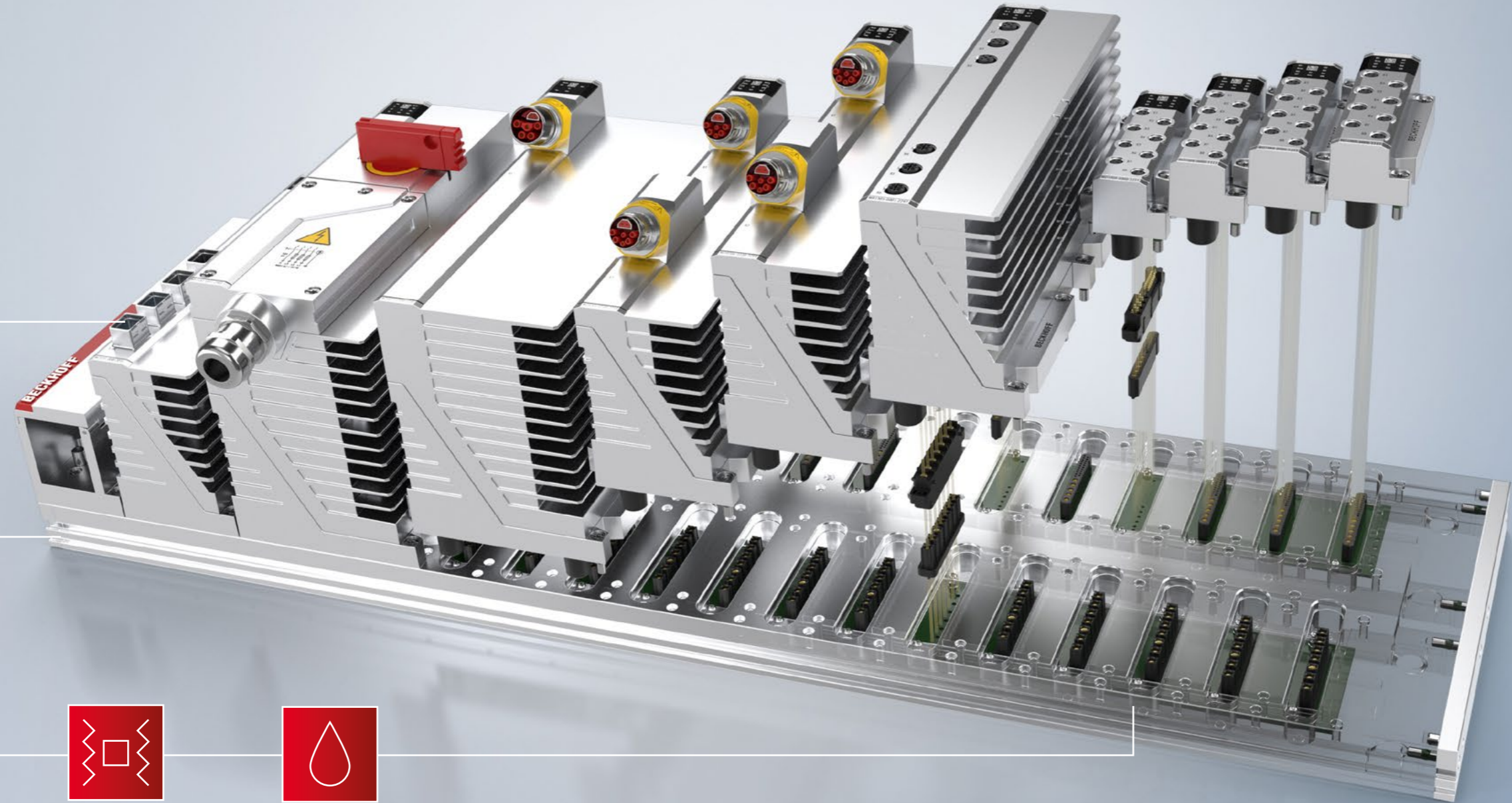

EtherCAT on board



bluetooth diagnosis



temperature



shock and vibration



dew point

## Data slot and distribution



- data connector (row 1)
- energy distribution 24/48 V DC
- EtherCAT
- 30 A (20 A per slot)

## Power slot and energy distribution



- power connector
- 400...480 V AC, 848 V DC
- 63 A (35 A per slot)



# Baseplates: Basis of the MX-System

The MX-System baseplates, which are available in three different sizes and equipped with standardized interfaces, form the basis of the MX-System as a back wall. They can be attached directly to the machine using screw connections and can thus be integrated into the machine installation space visually and functionally. The MX-System baseplates provide both the electrical and mechanical interface for accommodating the modules, and they have data interfaces (from size 1) as well as power interfaces (from size 2). In sizes 1 and 2, the baseplates are available with a minimum of six and a maximum of 24 slots. Starting from the smallest size with

six slots, the portfolio offers the possibility to configure MX-System baseplates in 2-slot steps. The MX-System baseplates in size 1 have data connectors only, thus only modules of the MS, MC and MO series can be used. The size 2 baseplates also feature power connectors so that the modules of the MD and MR series as well as more powerful MS and MC modules can be used additionally. Modules that have only one data connector can also be used on baseplates of size 2. Size 3 also offers these possibilities. The key feature, however, is the larger footprint, which is needed to accommodate particularly modules with notably intensive dissipation losses.

All three sizes of the baseplate are available in the variants of maximum flexibility as well as application-optimized. When an application-optimized baseplate is used, there are defined slots, e. g. for power modules, unlike a baseplate with maximum flexibility. All MX-System baseplates are made of a sturdy aluminum profile and have connection options for potential equalization. In addition to the housekeeping system integrated in all baseplates, an internal heating system and connection to a water cooling system are optionally available.

## Highlights:

- maximum flexibility
- application-optimized design
- optional extension of the system temperature range

1-row baseplate  
8 slots



2-row baseplate  
12 slots

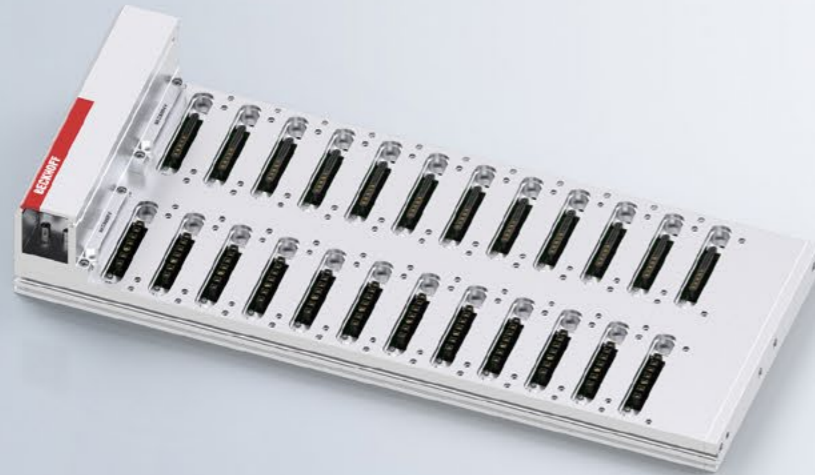

2-row baseplate  
application-optimized, 18 slots

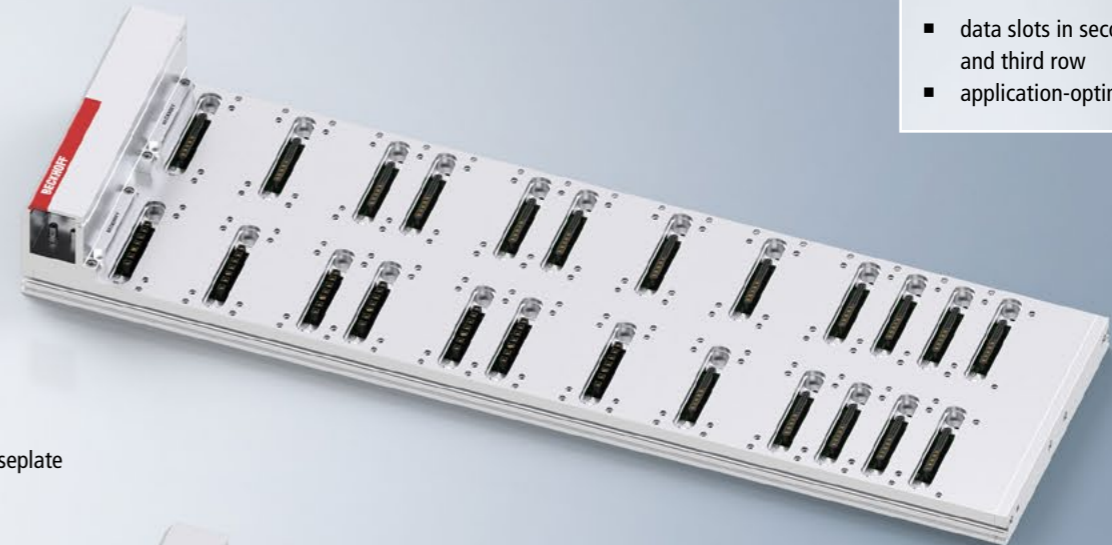

3-row baseplate  
18 slots

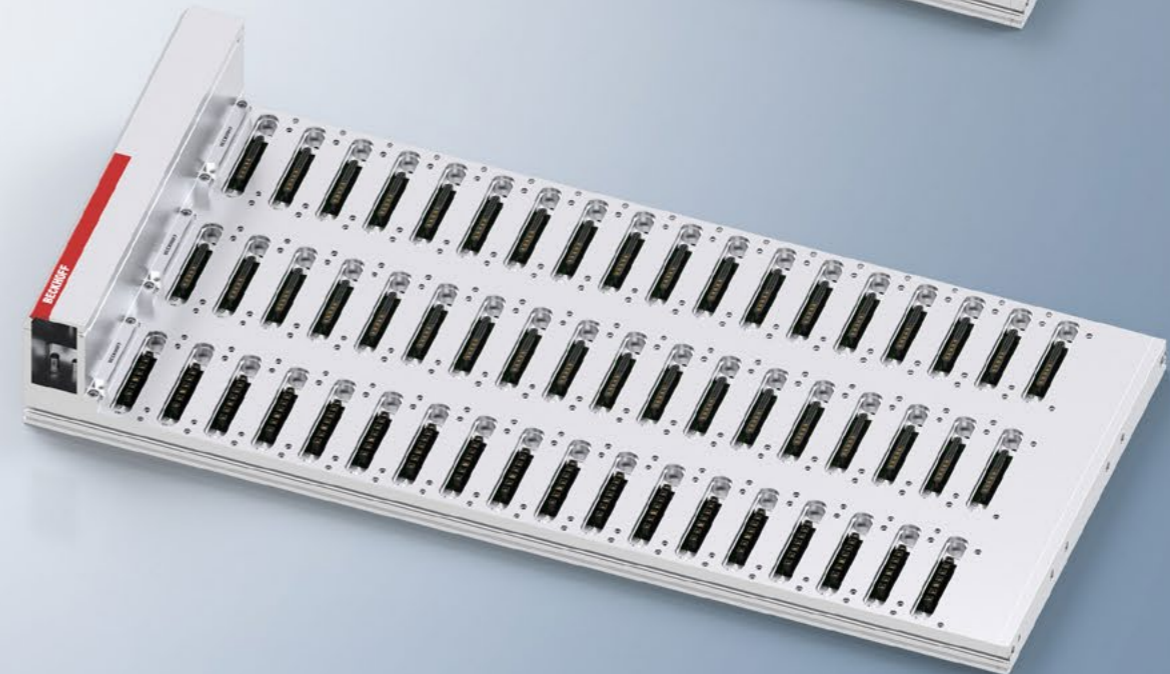

## Application-optimized design

- data slots in second and third row
- application-optimized slots

## Maximum flexibility

- up to 24 slots per row
- 1-row baseplate with data slots only
- 2- and 3-row baseplate with data and power slots



# IPC modules: Robust industrial PCs of various performance classes

Thanks to internal motherboard development and production, Beckhoff can offer high-performance and scalable industrial PCs optimized for the MX-System in a highly compact form, in robust IPC modules from the MCxxxx series. The IPCs of the MX-System represent a variety of performance classes and can be flexibly adapted to application-specific control requirements. The IPC modules take control of the function modules in the MX-System and provide programmers and end users with a familiar, reliable, flexible and scalable foundation for carrying out a wide range of automation tasks. A comprehensive portfolio of modern CPUs is available for this purpose and is being

continuously expanded. Likewise, technological trends in CPU development are carefully matched to industrial needs and implemented.

The MCxxxx series is available in the various sizes of the MX-System – depending on the thermal performance – and has a fixed slot in the system (first row, first slot), since as EtherCAT masters, they form the starting point of the EtherCAT segment. The IPC modules are powered via the 24 V supply of the data slot of the MX-System baseplate. The typical industrial PC interfaces for Ethernet, EtherCAT, UPS, display connection and USB are available on the front of the device as IP67 connections. The 24 V DC power

supply of an operator panel is optionally provided via a connection to the IPC or the MS81xx UPS module.

The access points integrated into the back of the modules for replacing batteries and mass storage devices, as well as a USB port specifically for a license key, are a special feature.

The CPUs of the MX-System are directly connected to the heat sink side of the aluminum housing via heatspreaders. This allows a fanless design of the MX-System IPCs.

Depending on the CPU type, the MC function modules offer Microsoft Windows or TwinCAT/BSD® operating systems. With TwinCAT as automation

software, the MX-System can cover the simplest PLC control tasks up to the most complex multi-core application with motion control, CNC, robotics, visualization, simulation, machine learning and much more.

## Highlights:

- fanless
- integrated 24 V supply for control panel
- rear USB ports for license keys

## Performance

- Intel® Celeron®, Intel® Core™ i3/i5/i7
- up to 8 cores, 2.6 GHz

## Efficiency

- Intel Atom®
- up to 4 cores, 1.9 GHz

## Low power efficiency

- ARM Cortex™-A53
- up to 4 cores, 1.2 GHz



# Coupler modules: Connection to external control architectures

In addition to being used as a master with an integrated PC-based control system, the MX-System can also be integrated as a device in external control architectures via the MKxxxx coupler modules. These can be EtherCAT systems as well as PROFINET-RT or EtherNet/IP networks. Integration into further Ethernet-based fieldbus protocols is also possible by using the corresponding coupler modules. If it is not an EtherCAT Coupler, a coupler module represents a gateway between the external network and the EtherCAT network within the MX-System. All coupler modules have one input and one output port each. This enables topologies in which

multiple MX-System stations are integrated into a higher-level network. It is also possible to integrate an EtherCAT segment consisting of several MX-System stations into other networks.

Coupler modules thus enable machines and systems to take advantage of the unique features of the MX-System regardless of the control technology used.

### Highlights:

- integration in all EtherCAT control architectures
- the advantages of the MX-System for Ethernet-based fieldbus protocols



EtherCAT Coupler

- connection to further EtherCAT networks



PROFINET RT Coupler

- connection to further PROFINET RT networks



EtherNet/IP Coupler

- connection to further EtherNet/IP networks



# I/O modules: For all signal types and directions

In line with the comprehensive Beckhoff I/O portfolio, the I/O function modules of the MX-System also offer a wide product range for all signals of the automation environment. Depending on the requirements, digital input and output signals can be processed or generated with the MO1xxx and MO2xxx modules. The MO3xxx and MO4xxx modules read in or output analog current/voltage signals. In many cases, the modules have configurable signal levels; partly also in combination with digital signals. With the modules of the MO5xxx series, complex signals from absolute and incremental encoders can be processed for precise measurement tasks in the area of position, frequency and

displacement/angle measurement. The I/O modules of the MO6xxx series are EtherCAT gateways. They are used to connect further fieldbuses such as IO-Link, PROFINET or EtherNet/IP. They also offer the possibility to establish simple serial RS232/RS485 communication to the corresponding devices. The I/O modules of the MO7xxx series are used for the connection of 24 V DC/48 V DC drive technologies such as servo, stepper and DC motors. Several TwinSAFE-capable I/O modules are available for recording, processing and outputting safety-relevant signals. Optionally, some I/O modules such as the IO-Link Class B master have an integrated, safe shutdown of voltage or control signals. With the compact MO7xxx drives, safe motion

functions can also be implemented with the aid of an optional safety card.

All I/O modules have an integrated electronic fuse. This ensures the line protection required by the standard by monitoring and limiting a maximum output power of 100 W. Due to the systematic use of microcontrollers, the I/O modules have a large number of diagnostic functions as well as diverse setting options.

## Highlights:

- integrated electronic fuse protection of the 24 V DC
- digitization of the 24 DC power demand
- integrated safety shutdown



### Digital input

- 2/4/8 channels
- potential-free
- ground switching
- timestamp
- counter

### Digital output

- 4/8 channels
- input/output configurable
- ground switching
- timestamp
- oversampling
- relay outputs

### Analog input

- common analog signals
- temperature
- measuring bridge
- acceleration

### Analog output

- 2/4/8 channels
- current/voltage
- signal type and level configurable

### Position measurement

- BiSS-C/SSI
- EnDat 2.2
- SinCos
- incremental

### Communication

- IO-Link
- PROFINET RT
- EtherNet/IP
- EtherCAT bridge
- RS422/RS485

### Compact motion

- stepper motor
- servomotor
- DC motor

### TwinSAFE modules

- digital inputs
- digital outputs
- relay outputs
- integrated TwinSAFE Logic



# Motion modules: Compact multi-axis systems for drives of all kinds

With the MD module series, the MX-System systematically capitalizes on a DC link system for all axis modules. For the control of synchronous servomotors and three-phase asynchronous motors, the MD8xxx and MD3xxx provide modules that are optimized for the respective task.

The MD6xxx modules are available for generating the DC link voltage. These take the 3-phase primary voltage from the backplane and feed the DC link voltage into the system. The MD6xxx modules ensure EMC category C2 in combination with the MS1xxx mains supply modules. In the simplest version, the modules have a connection for an external braking

resistor. Further variants cover the requirements of a controlled DC link as well as a mains regeneration. Another feature of the MD6xxx modules is the possibility to directly connect the decentralized servo axis system AMP8000. With the MS3xxx and MS4xxx system modules, the DC link voltage can be passed on to other MX-System stations.

In addition, the energy supplied is used in the best possible way: regenerative energy from deceleration processes is stored in the system's common DC link and is available again for subsequent acceleration processes. Optionally, the capacity of the DC link can be expanded using

the MD9xxx capacitor module: This leads to a reduction in the required connected load. Both the servo drives of the MD8xxx series and the frequency inverters of the MD3xxx series are available in single- and dual-axis versions. The central DC link system and the use of power semiconductors with optimized power dissipation reduce the space required and ensure a high power density. The MD8xxx series servo drives in the MX-System support Beckhoff's OCT One Cable Technology, with which only one connection cable is required for motor current and encoder feedback. All necessary information for control is transmitted interference-free

and reliably by means of a digital interface. The 1-axis servo drives and frequency inverters can optionally be equipped with interfaces for different encoder systems.

Both axis module variants feature STO/SS1 shutdown by an integrated TwinSafe safety module as standard. The servo drives also offer the "Safe Motion" option.

## Highlights:

- DC link system via multiple MX-System stations
- frequency inverter optimized for three-phase asynchronous motors
- power loss-optimized power semiconductors
- Safe Motion functionality

### DC link power supply

- generates DC link voltage up to 848 V DC
- 15 A/25 A/40 A rated output current

### Frequency inverter

- 1 or 2-axis
- 1...25 A rated output current
- STO/SS1

### Servo drives

- 1 or 2-axis
- 3...25 A rated output current
- STO/SS1 or Safe Motion

### Capacitor module

- supports the DC link
- 2025  $\mu$ F capacity





# Relay modules: Direct switching of high currents and powers

The relay modules MRxxxx round off the function module portfolio for connecting actuators and sensors of the MX-System. The relay modules MR1xxx allow direct switching of 230 V AC for lighting or fans, for example. The modules are also versatile due to the integrated digital I/Os. Three-phase asynchronous motors can be started directly with the mains voltage using the motor starter MR3xxx with up to 3 kW, or also operated in reversing mode. The control of a brake (24 V DC) and a thermal contact is possible with the modules and is provided in the connector. The solid-state modules MR4xxx can be used, for example, to operate electric heaters directly with

the MX-System. Due to the integrated analog input channels, control can be realized without additional components. The MR1xxx and MR4xxx modules are designed with 3 channels. The MR3xxx motor starters, on the other hand, are designed as 1 or 2-channel variants. The modules of the MR series permanently monitor and digitize the phase currents. This makes it possible to detect overcurrents and switch off devices internally at an early stage accordingly. The integrated fuses meet the normative requirements for power protection and provide short-circuit protection.

Due to the design, the possible replacement of the fuses can only be carried out in a safe con-

dition for the maintenance technician. Optionally, the modules of the MR1xxx and MR4xxx series can be equipped with a residual current measurement, combined with monitoring and shutdown within the module. This value is also available in the process image of the module via EtherCAT for the higher-level controller. The MR3xxx modules can optionally be equipped with a safe TwinSafe shutdown.

## Highlights:

- monitoring and digitization of phase currents
- integrated line protection
- integrated brake control
- integrated thermocouple control
- optional residual current measurement

### Relay

- up to 3 channels
- direct switching of 230 V AC

### Motor starter

- for 3-phases asynchronous motors
- 1-channel reversing starter with max. 7 A
- 2-channel direct starter with max. 3 A each

### Solid state relay

- 1 and 3-phases
- up to 10 A





# System modules: Power distribution and fieldbus connection

The infrastructure of the MX-System is ensured by various power infeed and output modules as well as by power supply modules. They perform different tasks that are required to enable a complete replacement of the control cabinet.

The MS1xxx power infeed modules have a wide range of properties and options. Primarily, they offer the possibility to connect the 3-phase system voltage to the system. For this purpose, a lockable terminal compartment with a corresponding cable gland is available in accordance with the specifications in the standard for the mains connection. The module also contains fuses and a 4-pin main switch. This can be locked

in position 0. Additional functions of the modules can be 24 V DC power supply units and energy measurement. In a simple variant, the mains voltage or also the 24 V DC can be made available to the MX-System via ECP/ENP connectors on the front side.

The MS2xxx power infeed modules are distinguished from the MS1xxx modules by an integrated bus coupler. In almost all cases, the modules use the ECP/ENP connector family, thus combining the connection of power and data lines. Optionally, the MS2xxx modules are available with integrated 24 V DC power supply units. However, the MS2xxx module portfolio also

offers the option of feeding 24 V DC, 48 V DC and EtherCAT into a size 1.

The MS3xxx power output modules distribute the different MX-System voltages to further MX-System stations or also to other systems. The modules each bundle the low voltages 24 V DC and 48 V DC as well as the high voltages 400 V AC and 600 V DC. All voltages are protected by appropriate fuses to meet the requirements of line protection. In the case of low voltages, the voltages can also be switched off. Recording, monitoring and digitization of the output current of the modules have also been implemented. Basically, the MS4xxx power output modules

have the same function. The range of functions is extended by the EtherCAT fieldbus and thus also enables EtherCAT P power outputs.

## Highlights:

- all-in-one power infeed
- integrated energy measurement
- outputs and inputs for EtherCAT and power based on One Cable Technology
- integrated line protection

### Power infeed

- connection of the 3-phase system voltage
- power infeed of max. 63 A

### EtherCAT power infeed

- 24 and 48 V DC, 10 A
- 400 V AC and 600 V DC, 25 A

### Power output

- 24 and 48 V DC, 10 A
- 400 V AC and 600 V DC, 25 A

### EtherCAT power output

- EtherCAT
- EtherCAT P
- 24 V and 48 V DC
- 400 V AC and 600 V DC



# System modules: Power supplies, switches, UPSs and extensions

With the MS6xxx series, 24 V DC power supply unit can be used as stand-alone modules. The parallel connection of power supply units can be conveniently set using the EtherCAT functionality, which is available in all power supply units. In addition to the 24 V DC power supply units, 48 V DC power supply units are also available. Power supply units are available for single-phase and three-phase AC voltages as well as for DC voltages of up to 848 V and in different performance classes. Further features are the active harmonic filters as well as a transient protection and the fuses for the input voltages. Optionally, the power supply units are also equipped with

additional ports on the front of the modules, e.g. for connecting AMI decentralized servomotors. The MS7xxx modules offer additional possibilities to map diverse Ethernet/EtherCAT topologies. The series includes, among other things, switches for Ethernet or junctions for EtherCAT.

The uninterruptible power supply is made possible by the MS8xxx modules: capacitive or battery-supported with 2 connections with UPS OCT communication especially for the communication and supply of the MX-System IPCs or also Beckhoff Panel PCs. Further components, among other things for bridging short-term mains voltage dips or also for supporting the

entire 24 V DC in order to be able to shut down systems in a controlled manner, are also part of the MS8xxx series.

Extensions are made via the MS9xxx empty housings: they allow the MX-System baseplate to be extended for the integration of special control units. The 400 V AC and 600 V DC connections of the power backplane are led out. The connections for EtherCAT, 24 V DC and 48 V DC of the data backplane are fused, additionally digital I/O signals are available for direct use.

## Highlights:

- PFC-regulated, EtherCAT and wide-range power supply units as standard
- UPS battery individually replaceable
- integration of control cabinet components possible

## Power supplies

- EtherCAT capable
- parallel connectable
- up to 848 V DC feedable
- input: 400 V AC/600 V DC
- output: 24 V DC/48 V DC, 10...20 A

## Ethernet/ EtherCAT infrastructure

- Ethernet switch
- EtherCAT junction

## UPS

- capacitive
- battery-supported

## Baseplate extension

- extension of the baseplate for the integration of special control devices
- 400 V AC and 600 V DC without fuse protection
- EtherCAT and 24 V DC/48 V DC with fuse protection

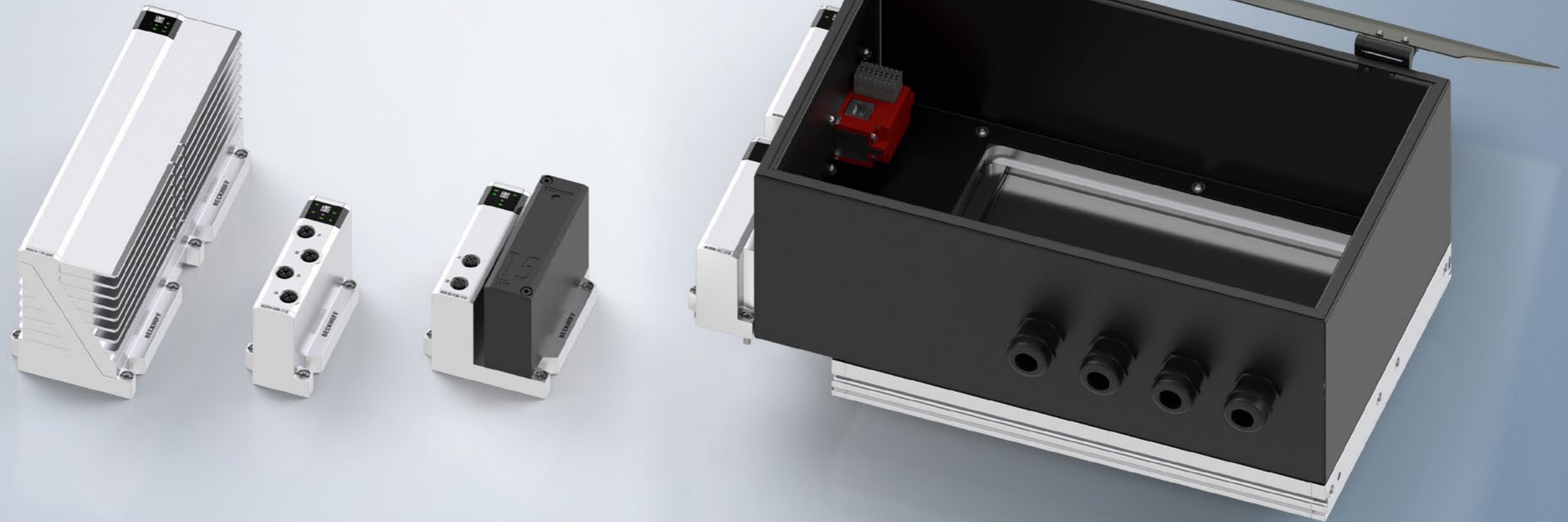



# Easy to install in two steps: Plug-and-play with the MX-System

Plug it in, screw it down, and you're done: The compact MX-System also sets new standards in handling and drastically reduces assembly times. The function modules are simply plugged onto the standardized connectors of the MX-System baseplate and then screwed in place using captive screws located in the modules. The time-consuming reading of a circuit diagram is no longer necessary; module interwiring is performed by the connector system. The MX-System can be set up by non-electricians.

Wiring errors are excluded by the modular principle – this automatically leads to an increase in quality. The smaller number of components

reduces the number of assembly steps and the required assembly area. Storage and production areas as well as logistics processes can be significantly streamlined.



**Step 1:**  
Plug module according  
to mounting plan



**Step 2:**  
Tighten module

## Highlights:

- plug-and-play installation with only one tool
- drastic reduction in the installation time
- more efficient processes





# The MX-System as an open, flexible automation system

The possible uses of the MX-System are flexible and can be precisely adapted to the requirements of any application at any time. On the one hand, the MX-System can be used as a stand-alone solution for automating a machine. On the other hand, it opens up numerous combination options: for example, it can be linked with other MX-Systems to create a decentralized, application-optimized automation solution. In combination with a control cabinet, an MX-System can be used as an energy distributor. Also possible: the combination with EtherCAT P products such as the EtherCAT P Box or the integrated AMP8xxx servo drive.

With the help of the corresponding MSxxxx modules, cascaded system structures in different topologies can easily be created. If production requirements change, owner-operators and machine builders can immediately react flexibly with the MX-System and subsequently integrate additional MX-System function modules or even entire stations.

## Highlights:

- complete replacement of the control cabinet
- distribution of functionality to several stations
- connection to existing control architectures
- integration of existing modules

## MX-System as independent automation system

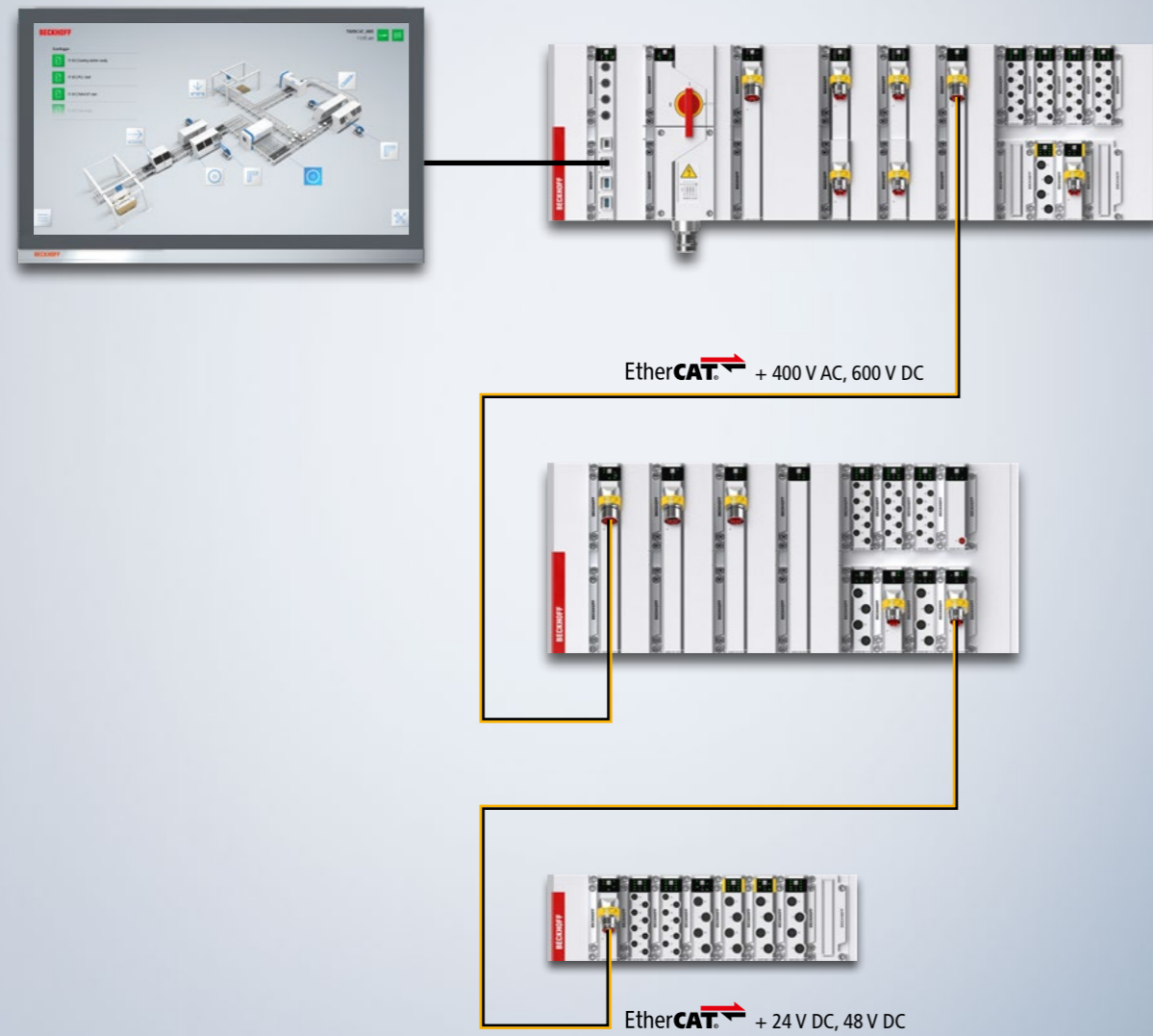

## MX-System integrated in existing architecture

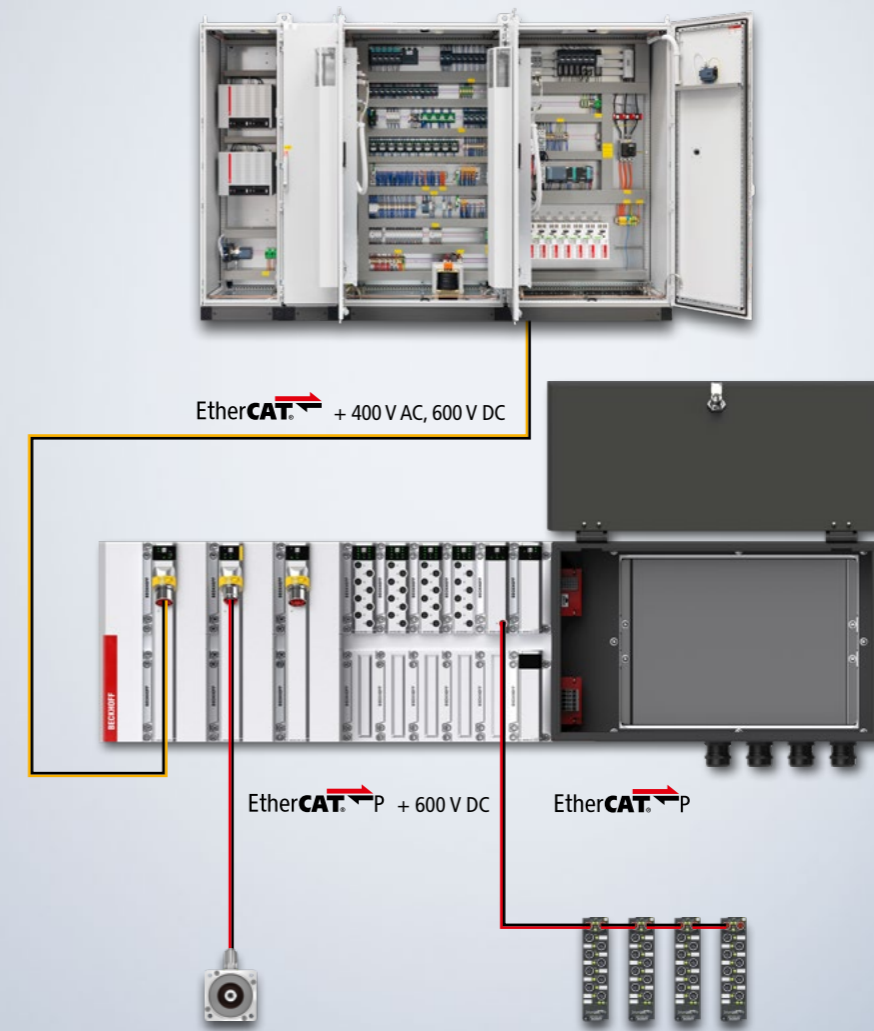



# Advantages throughout the entire machine life cycle with the MX-System

The optimally coordinated product portfolio makes it possible to design the electrical equipment of machines and systems according to modular principles. Since significantly fewer components than in traditional control cabinet construction are needed to implement the same requirements, the entire MX-System is more compact. Decentralized control concepts become feasible. Users are given a solution for UL, CSA and IEC that integrates functions such as safety, diagnostics and electronic fusing directly into the MX-System function modules.

In contrast to the classic control cabinet, neither housing nor manual wiring are necessary. The

standardized interfaces of the MX-System enable an effortless plug-and-play principle, as all function modules easily plug onto the baseplate. The installation time for a classic control cabinet can be drastically reduced with the MX-System. Installation can be carried out in-house by non-electricians, eliminating the need for external cabinet assembly and associated logistics. Errors in the wiring of the control cabinet are excluded.

The compact MX-System can be integrated directly into the machine installation space, thus reducing the machine footprint and shortening cable routes to the process level. Users benefit from the fast plug-and-play installation of all

cables thanks to ECP/ENP cables and connectors, and avoid installation errors. Electrical installation work can be carried out by qualified mechanics as part of the mechanical installation; qualified electricians are not required for the installation work. The space required for electrical components and cables is significantly reduced.

The fully integrated, non-intrusive EtherCAT components enable comprehensive system diagnostics at any time. This can be performed by non-electricians – no need to open a control cabinet. Fault localization for module, cable or device is simplified. The modular system and the simple plug-and-play principle also enable a defective

module to be replaced quickly and easily during operation, even by non-specialist personnel. This offers an enormous time advantage, especially for the end user/machine operator.



## Engineering

- design and planning according to modular principles
- decentralization and modularity
- functional safety, diagnostics, electronic fuse
- fewer components than conventional control cabinet solutions
- simplified circuit diagram
- visual, functional and space-optimized installation
- one solution for UL, CSA and IEC

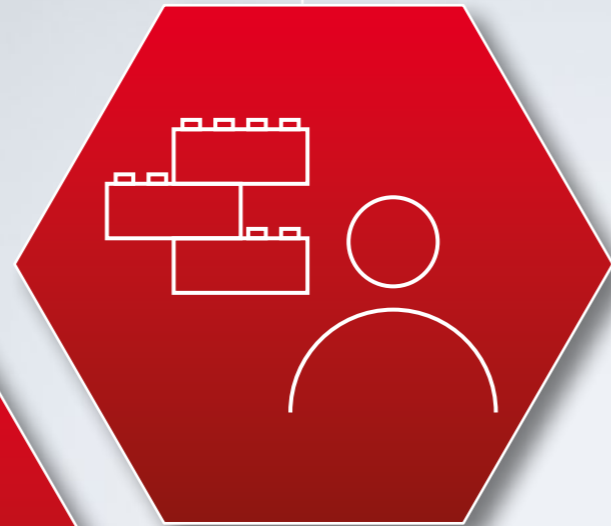

## System set-up

- effortless plug-and-play principle
- significant reduction in assembly time
- high quality: no wiring errors possible
- assembly can be performed in-house by non-electricians
- no external control cabinet assembly required
- straightforward logistics



## Electrical installation at the machine

- easy mounting directly on the machine
- low space requirement
- shorter cable runs
- plug-and-play installation of all cables and connectors
- no installation faults due to pre-assembled cables
- shorter installation time
- no need for electricians



## Service and maintenance

- fully integrated EtherCAT devices for system diagnostics
- diagnosis can be performed by non-electricians
- easy fault localization: module, cable, or device
- modules can be exchanged without special knowledge
- easy replacement of defective modules due to hot swap function
- unique part number diagnostics

# Advantages of the MX-System in figures

The MX-System integrates benefits over the full machine life cycle – from the initial planning of the machine through to series production: all efforts are reduced significantly. As the usually required circuit diagram of approx. 300 pages is reduced by 90% to now approx. 30 pages, the MX-System can be installed within one hour – a task that would normally take about 24 hours for a normal control cabinet. The number of personnel required for installation is also significantly reduced: instead of approx. 5 people, one non-specialist is sufficient here, and cable lengths and production space are also reduced. During operation, the availability of the machine

is increased: the simple and fast diagnosis shortens any troubleshooting, and individual modules can be replaced quickly and easily. The component count of the MX-System is cut by a factor of 10, thus reducing stock-keeping to a minimum.

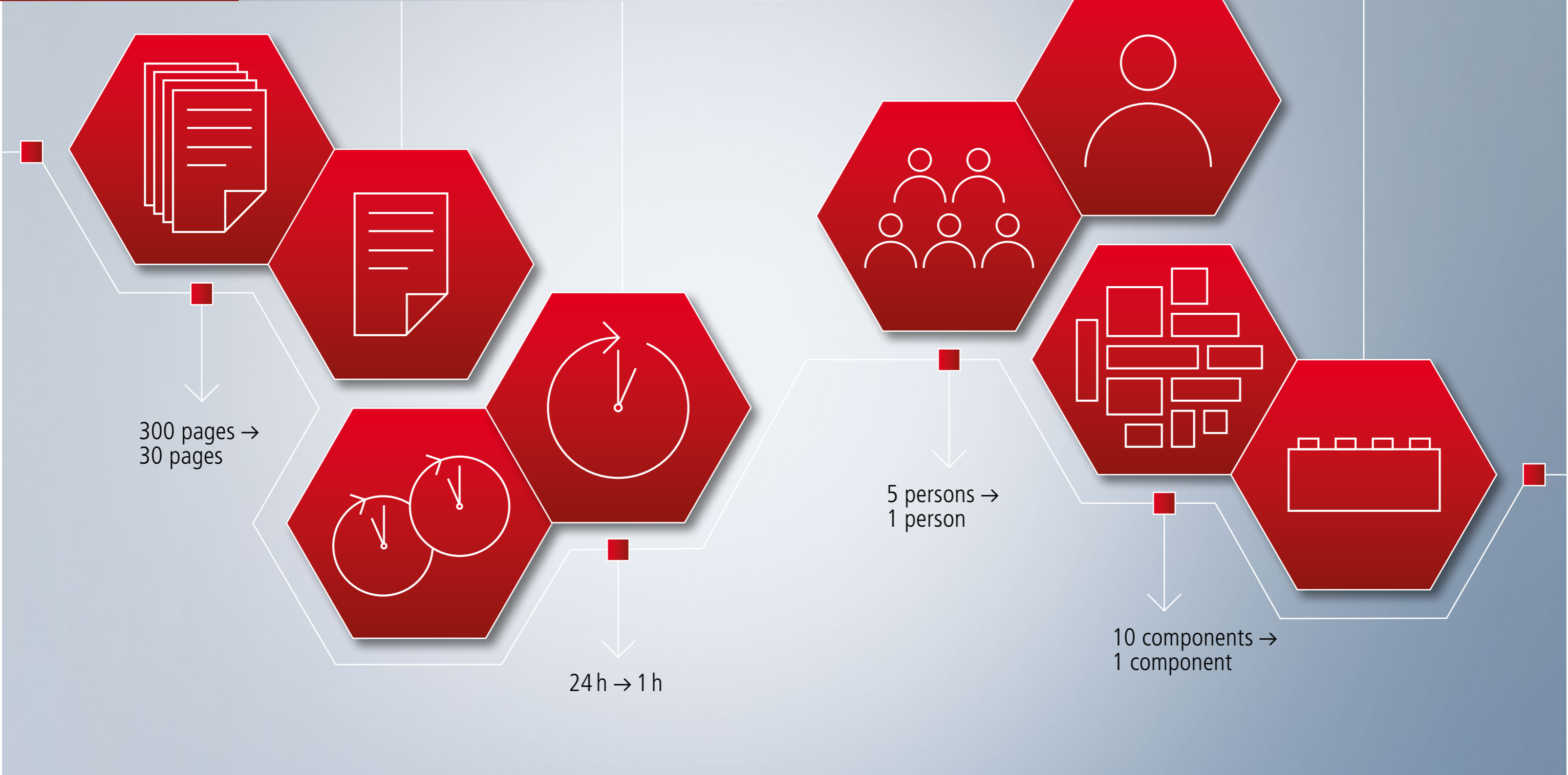



# The portfolio: Numerous functions for your MX-System

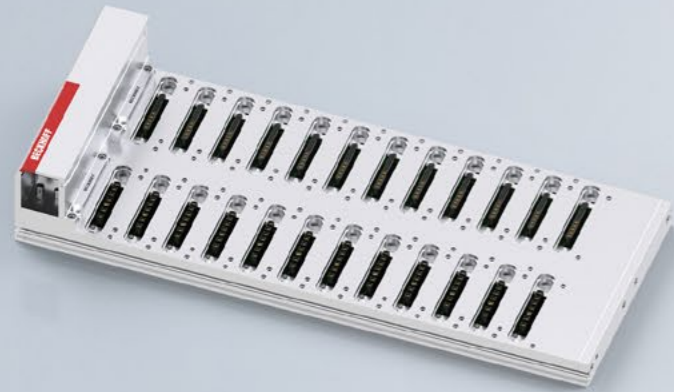

## Baseplates

### MB1xxx 1-row baseplate

up to 24 data slots, 24 V and 48 V DC distribution, EtherCAT, housekeeping

### MB2xxx 2-row baseplate

data and power slots, up to 24 slots per row, standard or application-optimized, 24 V/48 V DC and 400 V AC/600 V DC distribution, EtherCAT, housekeeping, integrated fans

### MB3xxx 3-row baseplate

2 rows of data slots, 1 row of power slots, up to 24 slots per row, standard or application-optimized, 24 V/48 V DC and 400 V AC/600 V DC distribution, EtherCAT, housekeeping, integrated fans

## IPC modules

### MC9040 low power efficiency

ARM Cortex™-A53, up to 4 cores, 1.2 GHz

### MC6015 efficiency

Intel Atom® X6xxxRE, up to 4 cores, 1.9 GHz

### MC6030 performance

Intel® Celeron®, Intel® Core™ i3, i5, i7, up to 8 cores, 2.6 GHz

## Coupler modules

### MK11xx EtherCAT Coupler

connection of the MX-System to other EtherCAT networks

### MK93xx PROFINET RT Coupler

connection of the MX-System to PROFINET networks

### MK95xx EtherNet/IP Coupler

connection of the MX-System to EtherNET/IP networks

## I/O modules

### MO1xxx digital input

up to 8 channels with different signal thresholds and functions, e.g. ground switching, timestamp, counter

### MO2xxx digital output

up to 8 channels with different output voltages and special functions, e.g. ground switching, timestamp, oversampling, PWM, pulse train, relay outputs and control of LED lightning

### MO3xxx analog input

with configurable channels (input/output) and different signal resolutions and special functions available, e.g. temperature, measuring bridge, IEPE sensor

### MO4xxx digital/analog combi

combined digital and analog signals with configurable channels, signal mix for voltage and current

### MO5xxx position measurement

1 or 2-channel for different encoders such as SSI, Sin/Cos, incremental

### MO6xxx communication

different interfaces such as IO-Link, PROFINET RT, EtherNet/IP, RS422/RS485

### MO7xxx compact motion

for different drive technologies such as stepper, servo and DC motors in low voltage up to 48 V DC with STO/Safe Motion

### MOx9xx TwinSAFE

different safety solutions: digital input, digital output, relay output

# The portfolio: Numerous functions for your MX-System



## Motion modules

### MD3xxx frequency inverter

up to 25 A rated output current, 1 and 2-axis, with STO

### MD8xxx servo drives

up to 25 A rated output current, 1 and 2-axis, with STO, OCT technology, optional: Safe Motion

### MD9xxx capacitor module

2025 µF, reduces the peak load of the the DC link power supply

### MD6xxx DC link power supply

generates DC link voltage  
optional with EtherCAT P output for AMP8xxx

## Relay modules

### MR1xxx relay

3-channel, 3 digital inputs, replaceable fuse

### MR3xxx motor starter

up to 7 A single-axis or 7 A (each) dual-axis, direct or reversing, replaceable fuse, optional with safe shutdown

### MR4xxx solid state

up to 16 A, 3-channel, 1- or 3-phase electric heater, replaceable fuse and analog inputs

## System modules

### MS1xxx power infeed

low/high voltage, optional: with compact or main switch, with forwarding

### MS2xxx EtherCAT power infeed

EtherCAT/EtherCAT P, low/high voltage, optional: with forwarding, 24 V power supply

### MS3xxx power output

low/high voltage, fused

### MS4xxx EtherCAT power output

EtherCAT/EtherCAT P, low/high voltage

### MS6xxx power supply

EtherCAT interface, power factor correction  
In: 400 V AC/600 V DC  
Out: 24 V DC/48 V DC/10...20 A

### MS7xxx Ethernet/EtherCAT infrastructure

Ethernet switch, EtherCAT junction, up to 4 channels

### MS8xxx UPS

capacitive or battery-supported with 24 V DC power supply

### MS9xxx baseplate extension

extension of the baseplate for the integration of special control devices







How can the MX-System revolutionize your production?

Get in touch to find out more.

► [www.beckhoff.com/mx-system](http://www.beckhoff.com/mx-system)



#### **Beckhoff Automation GmbH & Co. KG**

Hülshorstweg 20

33415 Verl

Germany

Phone: + 49 5246 963-0

[info@beckhoff.com](mailto:info@beckhoff.com)

[www.beckhoff.com](http://www.beckhoff.com)

Beckhoff®, TwinCAT®, TwinCAT/BSD®, TC/BSD®, EtherCAT®, EtherCAT G®, EtherCAT G10®, EtherCAT P®, Safety over EtherCAT®, TwinSAFE®, XFC®, XTS® and XPlanar® are registered trademarks of and licensed by Beckhoff Automation GmbH. Other designations used in this publication may be trademarks whose use by third parties for their own purposes could violate the rights of the owners.

© Beckhoff Automation GmbH & Co. KG 05/2022

The information provided in this brochure contains merely general descriptions or characteristics of performance which in case of actual application do not always apply as described or which may change as a result of further development of the products. An obligation to provide the respective characteristics shall only exist if expressly agreed in the terms of contract.

We reserve the right to make technical changes.