

Motorized Control Valves

Comfortable and Refreshing Indoor Environment



Global Flow Control Combination



TALOAR[®]

TALOAR INC
FLUID SYSTEMS, 2023

TC90 Series Room Temperature Controllers

TC 90 series is the new large-screen LCD temperature controller, mainly used for room temperature control of the fan-coil systems in industrial, commercial, and civilian central air conditioning units. It controls the terminal fan-coil control valves to perform opening and closing according to room temperature changes detected by the temperature-sensing elements of their thermometers. In that way, the room temperature is adjusted to provide a comfortable and energy-saving indoor environment.

TC90 series LCD temperature controllers adopt microcomputer control technology with large-screen LCDs. Statuses displayed on the LCD screen: Working status (cooling, heating, and ventilation), fan speed, room temperature, and set temperature. Keys: Power switch key (⏻), mode switch key (M), fan speed selection key (🌀), and temperature setting key (▲ ▼).



Product Features

Basic Functions

- Mode switching of cooling, heating, and ventilation.
- Manually or automatically controlled three-speed switch of the fan.
- Large-screen blue LCD backlight.
- Power-off memory function.
- Room temperature programming function, 4 periods per day.

Key Locking Function

The temperature controller is designed with the key locking function. It automatically locks the keys 30 seconds after the user stops operating it, restricting other people from operating the temperature controller.

Low-Temperature Protection Function

When room temperature is below 5°C, the closed temperature controller will turn on to warm up the room automatically and display the icon 🌞 on the screen. The fan will operate at high speed automatically, and then turn-on the motorized valve. The temperature controller will automatically turn off when room temperature rises to 7°C.

Temperature Adjustment

If the user wishes the temperature displayed on the temperature controller is higher or lower than the actual temperature ($\pm 5^{\circ}\text{C}$), the following operations can be performed:

When the temperature controller is off, press "▲" and "▼" at the same time for 3 seconds, and then "XX°C" will be displayed on the screen (the working mode of the temperature controller is not displayed). Then press "▲" or "▼" to adjust the temperature value, which will be automatically confirmed 6 seconds after the adjustment.

Alarm Function:

When the sensor fails, the temperature controller will turn off the fan and the motorized valve, and display "E1" or "E2" on the screen.

- E1: Sensor short-circuit alarm
- E2: Sensor open-circuit alarm

When temperature is higher than 55°C, "HI" will be displayed on the screen; when temperature is lower than 0°C, "LO" will be displayed on the screen.

Status Displayed On The Large-Screen LCD

- Working mode (cooling ❄️, heating ☀️, and ventilation 🌀)
- Fan speed (low speed 📊, medium speed 📊📊, high speed 📊📊📊, or automation AUTO)
- Motorized valve opening 🚪
- Room temperature display
- Temperature display setting

Technical Parameters

Temperature-Sensing Element: NTC
Temperature Control Accuracy: ±1°C
Temperature Setting: 5~35°C
Display Range: 0~55°C
Working Environment: 0~45°C
Humidity: 5 ~ 95% RH (no condensation)
Key: Press the keys gently.
Self-Consumed Power: < 1W

Power Supply Voltage: AC85~260V, 50/60Hz
Terminal Block: Can be connected to 2 * 1.5 mm² or 1 * 2.5 mm² wires
Load Current: 2 A (resistive load), 1 A (inductive load)
Shell: Fire-retardant PC + ABS
Dimensions: 90 * 88 * 15.5 mm (width * height * thickness)
Hole Pitch In Installation: 60 mm (standard)
Ingress Protection: IP30

Model Descriptions

TC90 – D/L2/L3/2C/3C/F4

- **D** Control the motorized air valve or the motorized air outlet.
- **L2** Control the motorized valve (two-wire valve) and the three-speed fan. When temperature reaches the specified value, close the motorized valve, leaving the fan to continue to run.
- **L3** Control the motorized valve (three-wire valve) and the three-speed fan. When temperature reaches the specified value, close the motorized valve, leaving the fan to continue to run.
- **2C** Control the motorized valve (two-wire valve) and the three-speed fan. When temperature reaches the specified value. The motorized valve and the fan will be closed.
- **3C** Control the motorized valve (three-wire valve) and the three-speed fan. When temperature reaches the specified value. The motorized valve and the fan will be closed.
- **F4** Applicable to the four-pipes system. Control the cooling/heating motorized valve (two-wires valve) and the three-speed fan. When temperature reaches the specified value, close the motorized valve, leaving the fan to continue to run.

Wiring Diagram

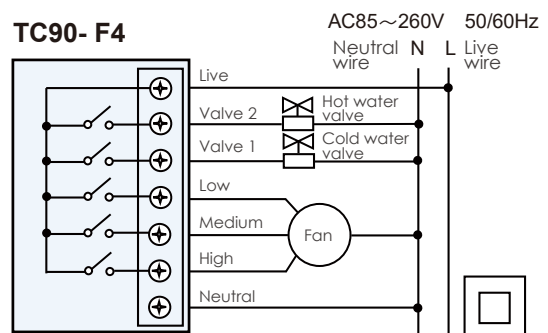
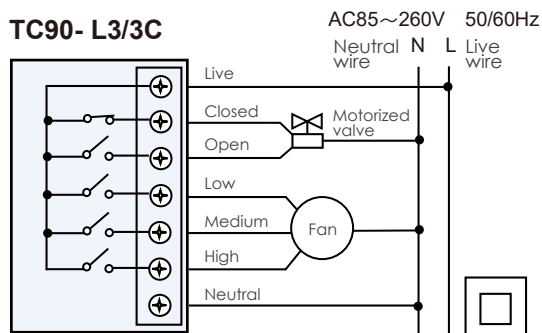
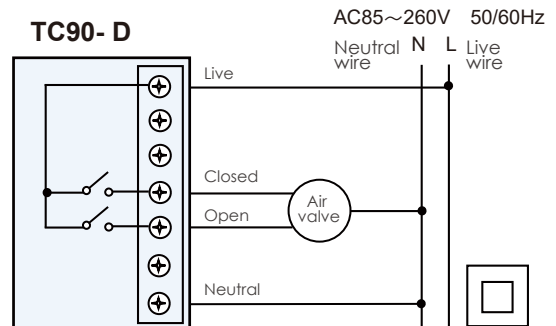
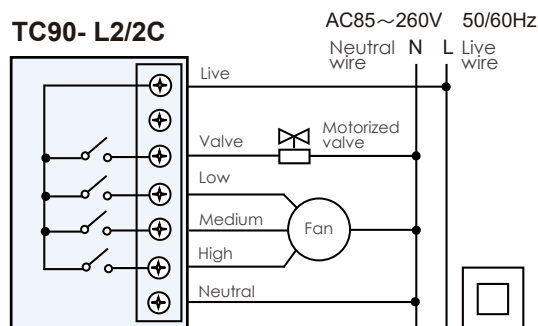

FC500 Series Fan-Coil Motorized Valves

FC500 series motorized two-way valves are mainly used to control the opening and closing of cold water and hot water in the terminal of the fan coil units of the air conditioning systems in order to provide a comfortable room temperature. When needed, the motorized valve will automatically turn on after receiving the control signal transmitted from the room temperature controller, then cool or warm the room as required. When temperature reaches the specified value, the room temperature controller will automatically cancel the transmitting signal, and the spring within the motorized valve will force it to turn off and bring it back to the original pre-set value.



Product Features

- Forged brass shell, stainless steel valve stem, and aluminum alloy bracket.
- Permanent magnet synchronous motor with a fully enclosed hysteresis clutch structure and spring reset.
- Synthetic rubber gasket to ensure zero leakage without any bubbles when closed
- Valve body design offers both a 2-way, normally closed type and a 3-way diverter type.
- Motor operates with low power consumption and minimal noise.
- The driver and valve body are separate, enabling quick and easy assembly and disassembly.
- Includes a built-in return spring and an optimized valve core structure.
- Threaded connections follow BSPT and NPT standards.
- Compact size, lightweight.

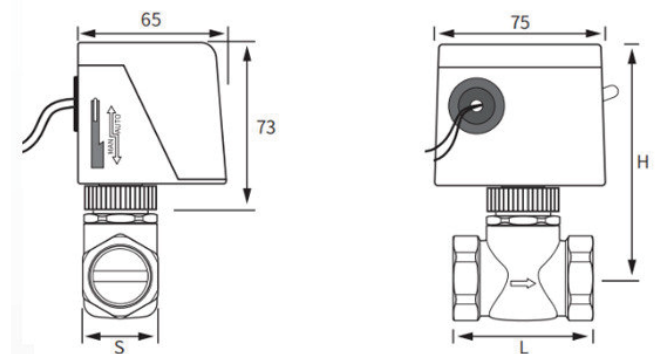

Technical Parameters

Power Supply Voltage: 220 VAC, 24 VAC ±10% 50 Hz

Power: < 6.5 W

Working Pressure: 1.6 Mpa

Medium: Water

Medium Temperature: 5°C ~ 90°C (40°F ~ 194°F)

Ambient Temperature: 0°C ~ 60°C (32°F ~ 140°F)

Action Time: Opening Time 10s, Closing Time 5s

Ingress Protection: IP40

Materials

Body: Brass

Shaft: Stainless Steel

Sealing: NBR or EPDM

Shell: High-strength flame-retardant ABS

Base: Aluminum Alloy

Spring: Stainless Steel

Flow Parameters

Model	Dimension (In)	Structure	Kv value	Differential pressure (MPa)
T215FC500	1/2"	Two-Way	1.0	0.20
T220FC500	3/4"	Two-Way	2.2	0.15
T225FC500	1"	Two-Way	3.5	0.08
T232FC500	1 1/4"	Two-Way	4.2	0.06

Dimensions/Weight

Model	L	H	S	Lbs	Kg
T215FC500	49	94	25.5	1.32	0.60
T220FC500	62	101	32.0	1.65	0.75
T225FC500	70	103	38.0	1.76	0.80
T232FC500	72	115	39.0	1.98	0.90

* Valves should be open when the system is pressurised.

Fc300 Series Fan-coil Motorized Heating Valves

FC300 series motorized-heating two-way valves are mainly used to control the opening and closing of cold water and hot water in the terminal of the fan coil units within the air conditioning systems in order to provide a comfortable room temperature of the fan coil units of the air conditioning systems in order to provide a comfortable room temperature. When needed, the motorized heating valve will automatically turn on after receiving the control signal transmitted from the room temperature controller, then cool or warm the room as required. When temperature reaches the specified value, the room temperature controller will automatically cancel the output signal, and the motorized heating valve will turn off slowly, cutting off the water source. FC300 series motorized heating valves are set to be powered off prior to delivery.

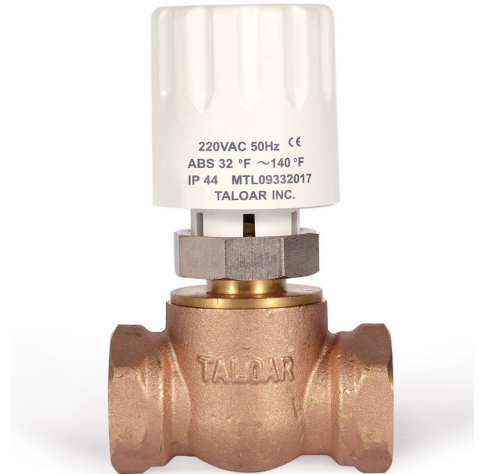

Product Features

- Forged-brass shell.
- Slow opening and closing, no noise, and reduced water hammer effect.
- Leak-free EPDM/PTFE sealing.
- The body structure is the normally-closed two-way type.
- The body comes with the spring return function.
- The actuator is connected to the ferrule of the body by a loose joint, easy to assemble.
- Thread standards: BSPT and NPT.
- Small size and light weight.

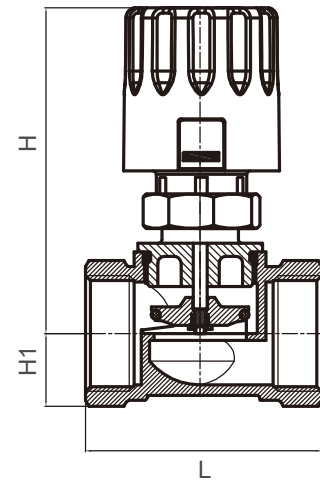

Technical Parameters

Power Supply Voltage: 230 VAC, 24 VAC ±10% 50 Hz
Power: < 3 W
Working Pressure: 1.6 Mpa
Medium: Water
Medium Temperature: 5°C ~ 90°C (40°F ~ 194°F)
Ambient Temperature: 0°C ~ 60°C (32°F ~ 140°F)
Action Time: 3 Minutes
Ingress Protection: IP44

Materials

Body: Brass
Disc: Brass
Shaft: Stainless Steel
Spring: Stainless Steel
Sealing: EPDM/PTFE
Shell: ABS Plastic

Flow Parameters

Model	Dimension (In)	Structure	Kv value	Cv value	Differential pressure (MPa)
T215FC300	1/2"	二通	2.2	2.5	0.20
T220FC300	3/4"	二通	3.0	3.5	0.18
T225FC300	1"	二通	6.9	8.0	0.15

Dimensions/Weight

Model/Dimension (mm)	L	H	H1	Lbs	Kg
T215FC300	66	94	16	0.57	0.26
T220FC300	66	94	18	0.66	0.30
T225FC300	68	94	22	0.93	0.42

M22 Radiator Temperature-control Valves

M22 temperature-control valves are energy-saving products that help to build a comfortable living environment. They are installed at the inlet ends of the radiators which control the inflow of the radiators according to the temperature signal received. The room temperature can then be adjusted as wished. The exquisite design of the valves complies with EN215 and the valves can be applied to various radiators.



Product Features

- Adjustment range can be locked or set at any time.
- Automatic control by the temperature sensor according to ambient temperature.
- Straight-through and right-angle body structures are available.
- The temperature-control valve's head and body are easily connected and can be replaced at any time.
- Externally threaded connector with a loose joint.
- The shell of the temperature-control valve's head is made of enhanced nylon + ABS plastic.
- Brass body, stainless steel shaft, and EPDM seat.
- Comply with EN215.

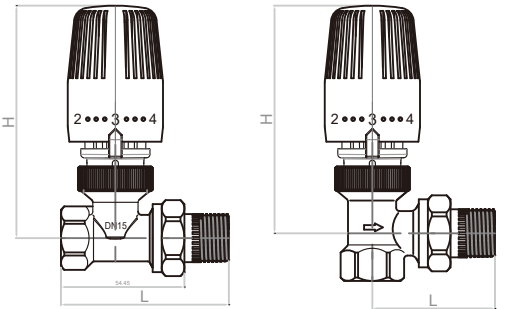

Technical Parameters

Working Pressure: 1.6 Mpa

Medium: Water

Ambient Temperature: -20°C ~ 50°C

Adjustment Range: 7°C ~ 28°C

Body Temperature: 5°C ~ 100°C



kvs Values

Regular Two-Pipe System Low-Resistance Single-Pipe System

1/2"	1.0	1/2"	2.6
3/4"	2.2	3/4"	3.8
1"	2.8	1"	4.6

Dimensions

Type/Dimension	In	H(mm)	L(mm)
Straight-Through	1/2"	102	79
	3/4"	105	94
	1"	107	94
Right-Angle	1/2"	100	54
	3/4"	102	62
	1"		

Installation And Application

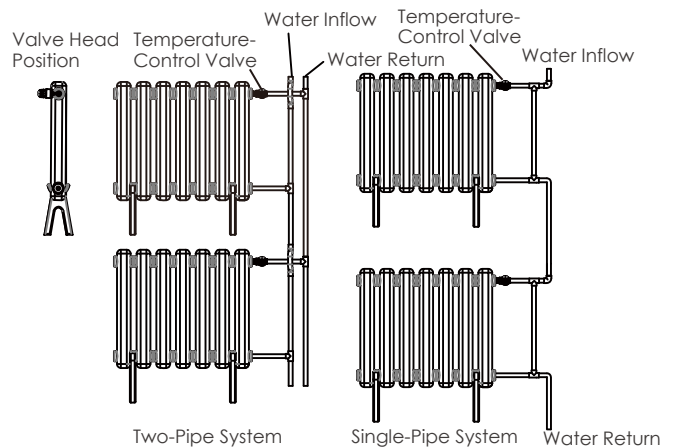

ES and BL Series Motorized Control Valves

Brass threaded motorized control valves of ES100/ES150 and BL220/BL350 series apply to HVAC (heating, ventilation, and air conditioning), and building automation systems. Once the motorized control valves receive signals transmitted by computers or other devices, they can then adjust temperature, pressure and control system parameters such as flow rate and liquid level. The valves are mainly used to convey mediums such as cold water, hot water, and ethylene glycol solution.

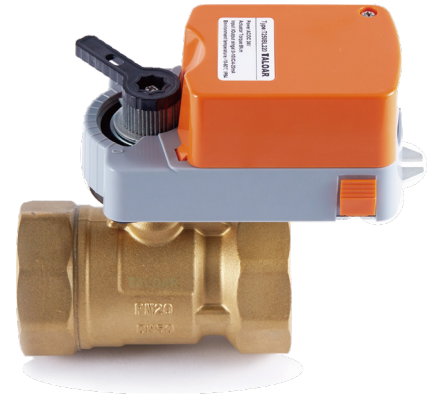

Product Features

- Have the equal percentage flow and the quick opening characteristics.
- The control valve's body has a built-in distribution plate that helps the flow control performance more stable.
- High-precision control offers precise actions.
- Low power consumption and low noise.
- Double O-shaped sealing design.
- Multiple signal controls: 2-point, 3-point, DC 0-10 V, and DC 4-20 mA.
- ABS shell with the advantages of small size and light weight.
- Easy installation and maintenance.

Technical Parameters

- Valve Type:** Two-way valve, three-way valve
Material: Shell: brass; dall: stainless steel; stem: brass
 sealing: RPTFE
Working Pressure: 2.0 Mpa
Medium: Cold water, hot water vapor, and the aqueous solution of ethylene glycol (concentration within 50%)
Medium Temperature: -20°C ~ 120°C
Flow Characteristic: Equal percentage curve, quick opening characteristic
Leakage Volume: Below 0.01% of kv value
End Type: BSPT of NPT threaded

Actuator Parameters

Electrical Parameters	Rated voltage	AC/DC 24V		AC 230 V
	Rated voltage range	AC 19.2..28.8V	DC 21.6..26.4 V	AC 184 ..2 76 V
	Power consumption	2.2W		3.2W
	Wire specification	4.4A		6.4A
	Terminal specification	Maximum: 2.0 m ²		
Function Parameters	Torque	4Nm/8Nm		
	Suitable ball valve	4Nm: ½" ~ 1-½" ; 8Nm: 1-¼" ~ 2"		
	Manual operation	Press the manual button and then manual operation is available.		
	Rotation angle	Maximum: 95°, mechanically adjustable		
	Running time	70 s (no load)		
	Noise	45dB		
Working Environment	Appliance class	III (low-voltage and safe)	II (double insulated)	
	Ingress protection	IP44		
	Working temperature	-20 ~ +50°C		
	Humidity testing	95%RH, no condensation		

Dimensions

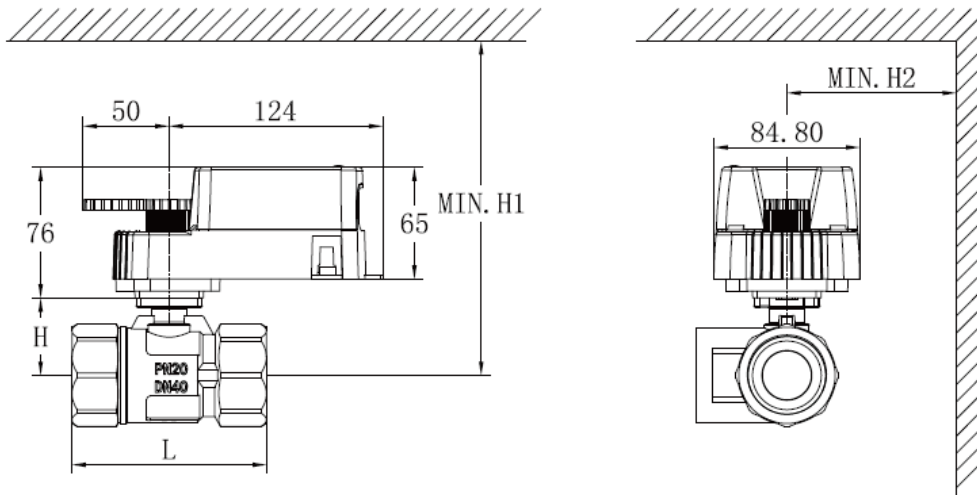

Model/Dimension	mm	In	mm		Minimum installation space	
			L	H	H1	H2
T215ES100/BL220	15	1/2	63	30	180	72
T220ES100/BL220	20	3/4	73	35	185	72
T225ES100/BL220	25	1	94	38	188	72
T315ES150/BL350	15	1/2	63	32	180	72
T320ES150/BL350	20	3/4	66	35	185	72
T325ES150/BL350	25	1	94	38	188	72

Model/Dimension	mm	In	mm		Minimum installation space	
			L	H	H1	H2
T232ES100/BL220	32	1-1/4	108.5	43.5	190	80
T240ES100/BL220	40	1-1/2	117	48	195	80
T250ES100/BL220	50	2	139	53	200	80
T332ES150/BL350	32	1-1/4	98.5	43.5	190	80
T340ES150/BL350	40	1-1/2	106	48	195	80
T350ES150/BL350	50	2	123	53	200	80

Flow Characteristics

Thermal Output Characteristics

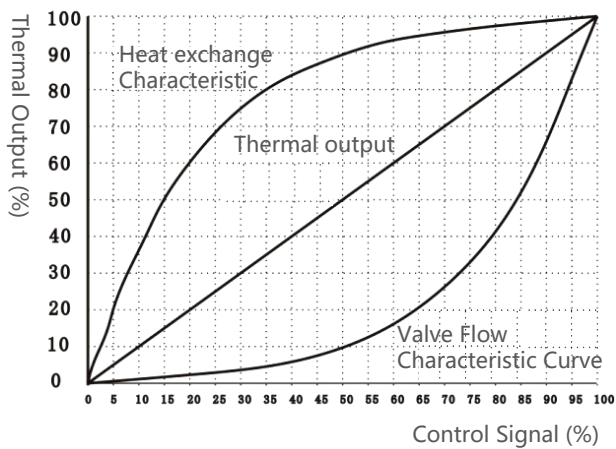

Measured Valve Flow Characteristic

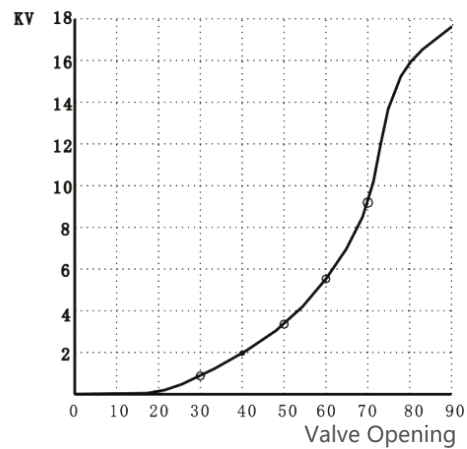

Valve Selection

ΔPmax: The maximum allowable differential pressure when the valve is fully opened under normal working conditions.

ΔPmax: The maximum allowable differential pressure under low-noise condition.

ΔP100: Differential pressure when the ball valve is fully opened.

V100: Rated flow rate when the differential pressure is at ΔP100.

$$v_s = \frac{K_{100}}{\sqrt{\frac{\Delta P_{100}}{100}}}$$

- DN-Kvs
- DN50-63
 - DN50/DN40-40
 - DN40/DN32-25
 - DN32/DN25-16
 - DN15/DN20/DN25-10
 - DN20/DN15-6.3
 - DN20/DN15-4

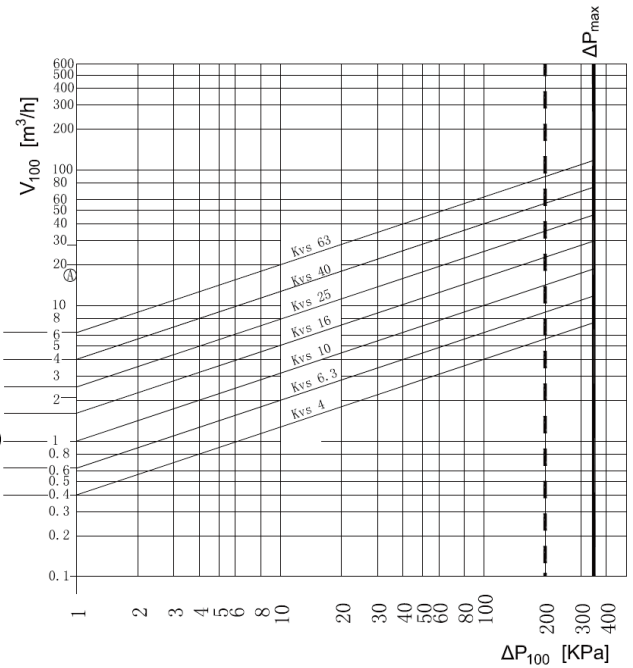

Maximum allowable differential pressure ΔPmax:

0.4 Mpa (0.2 Mpa is the differential pressure under low-noise operation)

Shutoff pressure differential ΔPs: 1.4 Mpa

Note: Shutoff differential pressure ΔPs: The shut-off differential pressure when the actuator is fully closed with the allowable leakage.

Electrical Wiring Diagrams

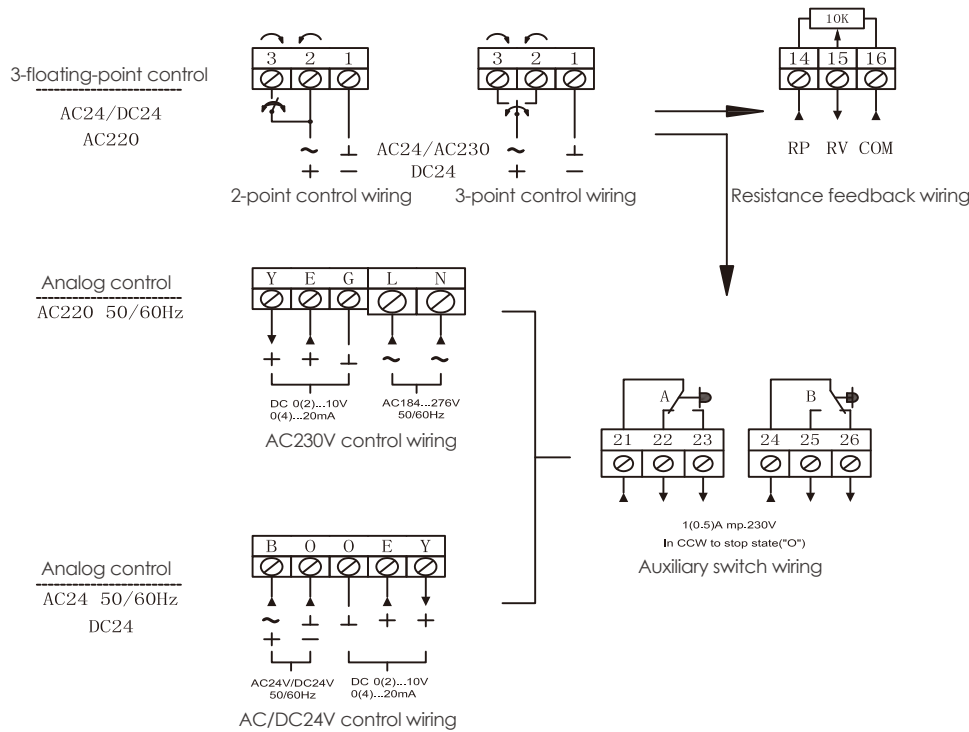

UL and AF Series Motorized Control Valves

Stainless-steel threaded motorized control valves of UL330/350 and AF550/572 series apply to HVAC and building automation systems. Once the motorized control valves receive signals transmitted by computers or other devices, they can then adjust temperature, pressure and control system parameters such as flow rate and liquid level. The valves are mainly used to convey mediums such as cold water, hot water, and ethylene glycol solution.



Product Features

- Adopt the AC synchronous hysteresis clutch motor. When the limited position is reached, the hysteresis clutch disengages the motor's output shaft from the transmission part to protect the motor.
- High-precision control offers precise actions.
- Low power consumption and low noise.
- Have the self-adaptive valve travel function.
- Multiple signal controls: Increment/floating-point signal, voltage 0 - 10 V, current 4 - 20 mA.
- ABS shell and cast-aluminum bracket with the advantages of small size and light weight.
- Easy installation and maintenance.

Technical Parameters

- Valve Type:** Two-way valve, three-way valve
Material: Shell: stainless steel; disc/stem: stainless steel; sealing: RPTFE
Working Pressure: 2.5 Mpa
Medium: Cold water, hot water, vapor, and the aqueous solution of ethylene glycol (concentration within 50%)
Medium Temperature: 0°C ~ 110°C/0°C ~ 150°C with a heat dissipation device
Flow Characteristic: Equal percent curve/equivalent linear
Leakage Volume: Below 0.02% of Kv Value
End Type: BSPT or NPT threaded

Actuator Parameters

Item	Performance parameters	
	UL series (incremental control model)	AF series (proportional adjustment model)
Power Supply	AC 24 VAC/220 VAC ± 10%, 50 Hz/60 Hz	
Force	500N, 1000N	
Power Consumption	< 5.5VA	
Operating Speed	0.20mm/s (50Hz)	
Control Signal	Increment/floating-point signal	0 ~ 10VDC or 4 ~ 20 mA
Working Temperature	-10°C ~ 50°C (50°F ~ 120°F)	
Humidity	10% ~ 90% RH, no condensation	
Maximum Travel	25 mm	
Actuator Weight	2.4Lbs/1.1 kg ; 2.7Lbs//1.2 kg	
Materials Of Main Parts	Fire-retardant ABS plastic shell and die-cast aluminum bracket	
Waterproof Rating	IP54	
Power-off State	Stay in the current position	
Valve Opening Before Delivery	Middle position	
Manual Function	Have manual operation	
Valve Opening Indication	Have valve opening indication	
Insulation Resistance	Resistance between the power supply terminal and the shell: ≥ 50 MΩ; that between the input terminal and the shell: ≥ 20 MΩ.	
Dielectric Strength	Dielectric strength between the power supply terminal and the shell: 500 V, 50 Hz for AC24V equipment; 1,500 V, 50 Hz for AC220 equipment; that between the input terminal and the shell: 500 V, 50 Hz	

Dimensions

15 2025m 3240mm 50mm

In		½	¾	1	1 ¼	1 ½	2
mm		15	20	25	32	40	50
L		85	85	90	105	120	140
H	Two-way valve	81	81	85	95	111	123
	Three-way valve	100	100	106	113	131	156
H1	Two-way valve	41	41	39	43	51	56
	Three-way valve	60	60	60	61	70.5	88.5
H2	Two-way valve/three-way valve	40	40	46	52	60	67
H3	Two-way valve/three-way valve	246	246	252	258	266	273

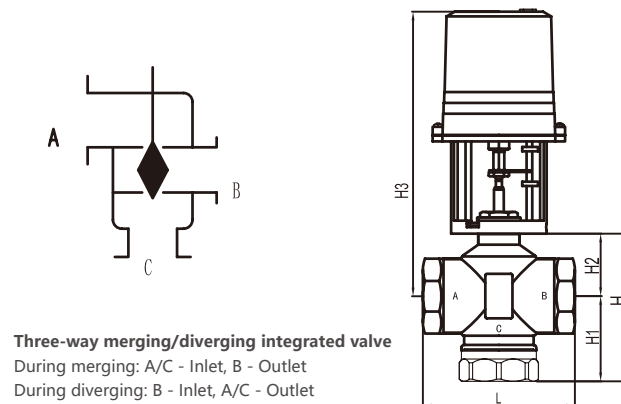
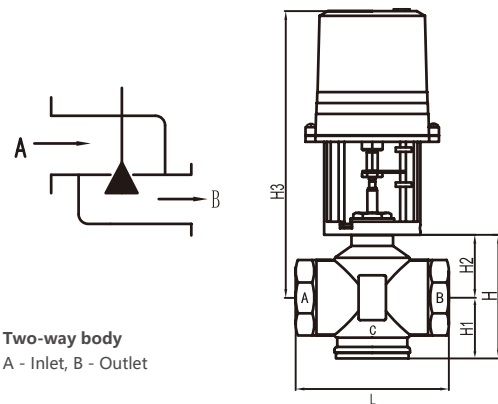

Note: Please note that the flow direction of the medium in pipelines is the same as the direction of the valve body's arrow during design and installation.

Kv (Flow Rate Value), Travel, and Close-Off Differential Pressure

Dimension (In)	Kv value (m³/h)	Travel (mm)	Closed-off differential pressure (MPa) two-way/three-way	
			500N	1000N
½	3	13	0.35	0.70
¾	5	13	0.35	0.70
1	8	13	0.30	0.65
1¼	13	13	0.23	0.60
1½	21	19	0.19	0.47
2	35	19	0.15	0.30

Note: The closed-off differential pressure listed in this table refers to the calibration value when the medium is water at 25°C.

Electrical Wiring Diagrams

Applicable to AC 24 V incremental control models

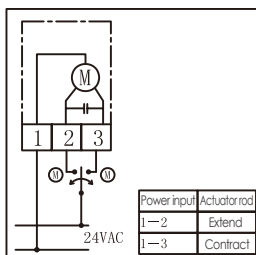

Applicable to AC 24 V analog control models

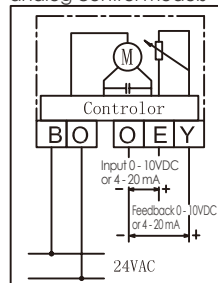

Applicable to AC 220 V incremental control models

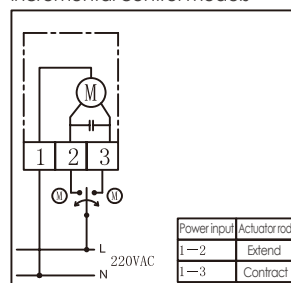

Applicable to AC 220 V analog control models

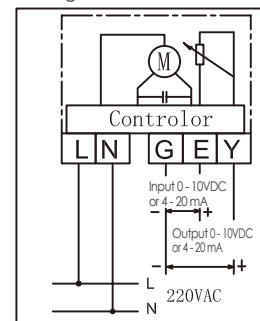

Applicable to all actuator models with passive contacts

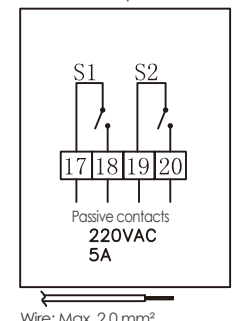

VF and NL Series Motorized Control Valves

Ductile iron motorized control valves of VF730/750 and NL800/870 series apply to HVAC and building automation systems. Once the motorized control valves receive signals transmitted by computers or other devices, they can then adjust temperature, pressure and control system parameters such as flow rate and liquid level. The valves are mainly used to convey mediums such as cold water, hot water, and ethylene glycol solution.



Product Features

- **Adopt the AC synchronous hysteresis clutch motor.** When the limited position is reached, the hysteresis clutch disengages the motor's output shaft from the transmission part to protect the motor.
- **High-precision control offers precise actions.**
- **Low power consumption and low noise.**
- **Have the self-adaptive valve travel function.**
- **Multiple signal controls: Increment/floating-point signal, voltage 0 - 10 V, current 4 - 20 mA.**
- **ABS shell and die-cast aluminum bracket with the advantages of small size and light weight.**
- **Easy installation and maintenance.**

Technical Parameters

- Valve Type:** Two-way Valve/three-way Valve
Material: Shell: ductile iron; disc/stem: stainless steel;
 Sealing: RPTFE
Working Pressure: 1.6 Mpa/2.5 Mpa
Medium: cold water, hot water, and the aqueous solution of ethylene glycol (concentration within 50%)
Medium Temperature: -10°C ~ 120°C/-10°C ~ 180°C with a heat sink
Flow Characteristic: Equal percentage curve/equivalent linear
Leakage Volume: Below 0.02% of kv value
End Type: Flanges (ANSI B16.1/16.5 or EN1092)

Actuator Parameters

Item	Performance parameters	
	VF series (incremental control model)	NL series (proportional adjustment model)
Power Supply	AC 24 VAC/220 VAC ± 10%, 50 Hz/60 Hz	
Motor	AC synchronous motor	
Force	1000 N, 1500 N, 3000 N	
Power Consumption	6 -18 VA	
Operating Speed	1¼" -2" 0.20 mm/s (1000 N) 2½" 0.25 mm/s (1500 N) 4" - 8" 0.32 mm/s (3000 N)	
Control Signal	Increment/floating-point signal	0 ~ 10VDC or 4 ~ 20 mA
Working Temperature	-10°C ~ 50°C (50°F ~ 120°F)	
Humidity	10% ~ 90% RH, no condensation	
Maximum Travel	1000N 22mm; 1500N 22mm; 3000N 55mm; 6500N 60mm; 10000N 100mm	
Actuator Weight	1000N 2.7Lbs/1.2 kg; 1500N 3.3Lbs/1.5 kg; 3000N 7.7Lbs/3.5 kg	
Materials Of Main Parts	Fire-retardant ABS plastic shell and die-cast aluminum bracket	
Waterproof Rating	IP54	
Valve Opening Before Delivery	Middle position	
Manual Function	Have manual operation	
Valve Opening Indication	Have valve opening indication	
Insulation Resistance	Resistance between the power supply terminal and the shell: ≥ 50 MΩ; that between the input terminal and the shell: ≥ 20 MΩ.	
Dielectric Strength	Dielectric strength between the power supply terminal and the shell: 500 V, 50 Hz for AC24V equipment; 1,500 V, 50 Hz for AC220 equipment; that between the input terminal and the shell: 500 V, 50 Hz	

Dimensions

In	1 ½	2	2 ½	3	4	5	6	8	10	
mm	40	50	65	80	100	125	150	200	250	
L	200	230	290	310	350	400	480	495	622	
H	Two-way valve	165	175	215	235	265	295	320	405	489
	Three-way valve	242	259	273	291	323	363	395	492	643
H1	Two-way valve	329	332	333	344	421	437	451	475	938
	Three-way valve	329	332	333	344	421	437	451	475	938
H2	Two-way valve	79	86	125	134	154	168	179	240	241
	Three-way valve	156	170	183	190	212	236	254	327	395
D	150	165	185	200	220	250	295	340	405	
K	110	125	145	160	180	210	240	295	355	
Number of flange holes and number of bolts	4-M16	4-M16	4-M16	8-M16	8-M16	8-M16	8-M20	12-M20	12-M24	

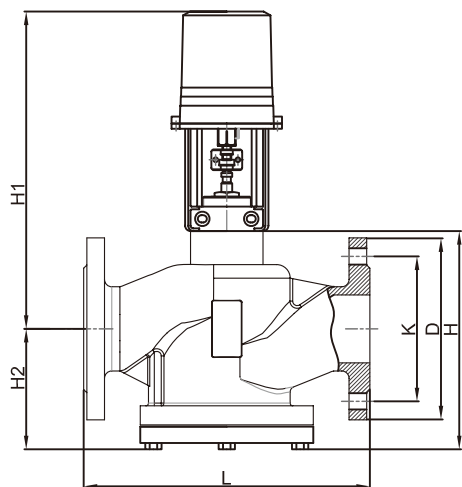

Motorized two-way control valve

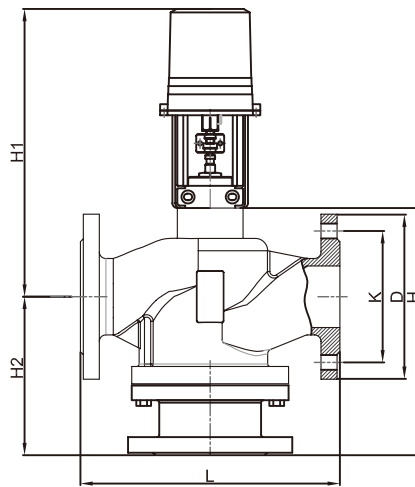

Motorized three-way control valve

Flow Direction of Medium

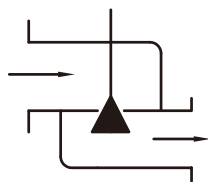

Two-way valve

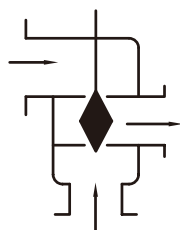

Three-way merging valve

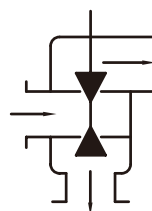

Three-way diverging valve

Note: Please note that the flow direction of the medium in pipelines is the same as the direction of the valve body's arrow during design and installation.

Kv (Flow Rate Value) and Close-Off Differential Pressure

In	1½	2	2½	3	4	5	6	8	10
mm	40	50	65	80	100	125	150	200	250
Kv value (m³/h)	21	35	52	88	140	200	280	410	630
Close-off differential pressure (MPa)	0.47	0.30	0.40	0.30	0.35	1.0	1.0	1.0	0.2
Force	1000N		1500N		3000N			6500N	

Note: The closed-off pressure differential listed in this table refers to the calibration value when the medium is water at 25°C.

Electrical Wiring Diagrams

Applicable to AC 24 V incremental control models

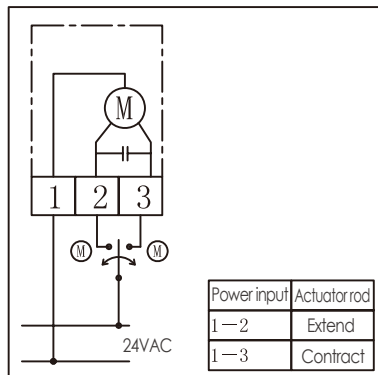

Applicable to AC 24 V analog control models

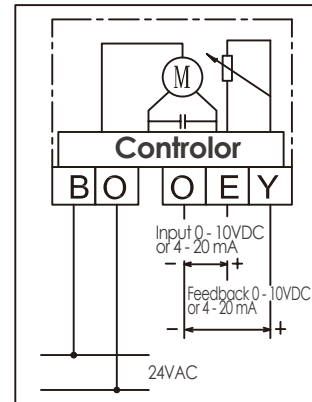

Controller

Applicable to AC 220 V incremental control models

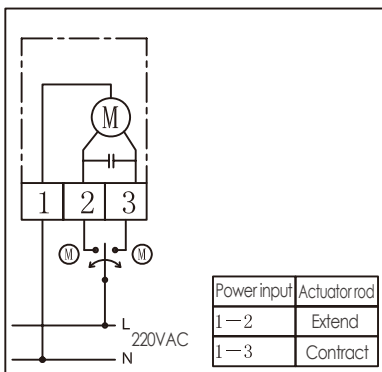

Applicable to AC 220 V analog control models

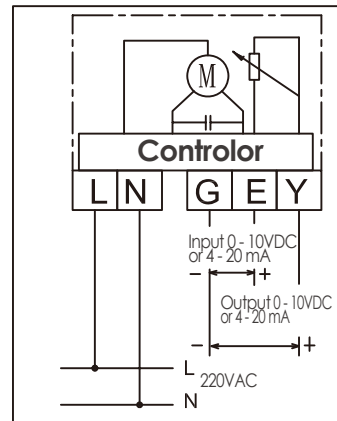

Applicable to all actuator models with passive contacts

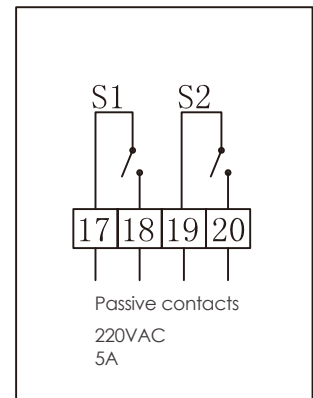

Wire: Max. 2.0 mm²

Note: The power switch must be closed during the normal operation of the actuator, and it is strictly forbidden to run the actuator when it is not connected to the valve body.

Fire Protection

Resilient Wedge Gate Valve
Indicator Post
Butterfly Valve
Fire Hydrant
UL/FM



Oil Refining

Gate Valve
Globe Valve
Trunnion Ball Valve
High Performance Butterfly Valve
Plug Valve
API 609 API 6D



Power Plant

Metal Seal Ball Valve
Gate Valve
Globe Valve
Needle Valve
CS, FS, SS



Shipping

Bronze Valve
Butterfly Valve
Gate Valve
Ball Valve
Check Valve



Our Business



Water Treatment

Flanged Butterfly Valve
Knife Gate Valve
Check Valve



HVAC Systems

Hydraulic Balancing Valve
Differential Pressure Valve
Motorized Valve
Temperature Control
Bronze Valve & Iron Valve



Chemical

Bellows Globe Valve
Angle Valve
Metal Seal Ball Valve
High Performance Butterfly Valve



Irrigation

Solenoid Control Valve
Pressure Reducing Valve
Pressure Relief Valve
Diaphragm Valve
Butterfly Valve
Gate Valve





TALOR[®]

TALOR INC.,

1220N.Market Street,
Delaware,USA.
PHONE: +1/302.327.8999
www.taloor.com